

LEANPOST 2200

Electric handling trolley

LOGISTICS

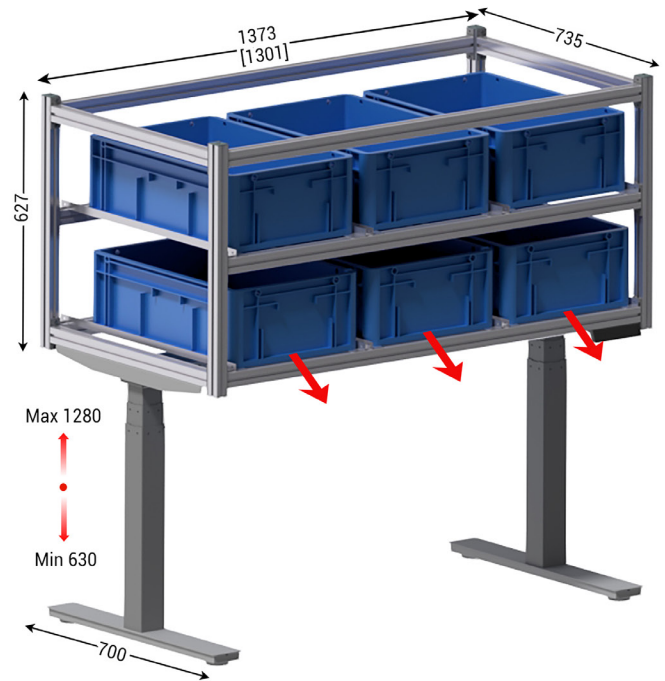
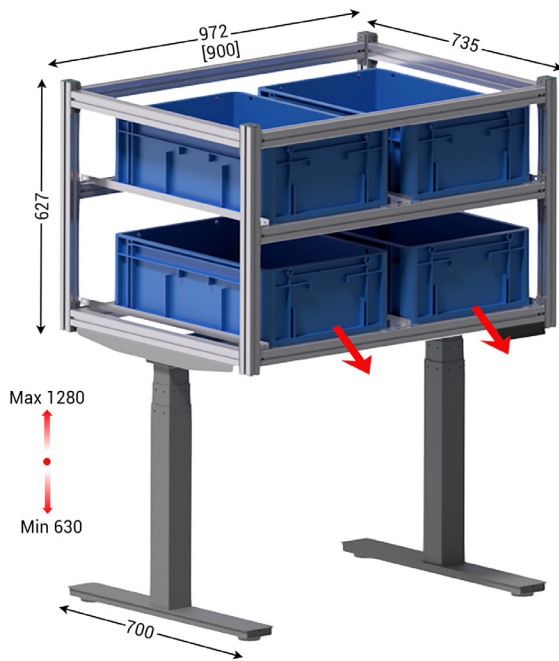

The **electric handling trolley** LEANPOST 2200 brings great comfort to the operator's work. It is a LEAN tool to facilitate the movement of 600 x 400 mm format bins.

Handling the bins is made easier thanks to the electrical height adjustments, allowing all the boxes to be placed at the right level. The LEANPOST 2200 allows effortless sliding (instead of carrying the container) to improve working conditions and QVT (Quality of Life at Work). The operator's spine is less stressed and the risk of musculoskeletal disorders is reduced. Our research and development department is at your disposal to assist you with all your projects.

- Easy and quick adjustment thanks to its remote control fixed under the top. Possibility of memorizing 4 positions
- Ground support on 4 height-adjustable glides
- Two electrical columns, 120/230 Volt power supply
- Allowable overall load: 100 kg for a capacity of 4 or 6 bins 600 x 400 mm depending on the model

Accessories



	CODE	DESIGNATION	LEAD TIME	PACKING
	652209	W 900 x D 700 x H 630 - 1280 mm 2 levels for 4 bins 600 x 400 mm	25 days	In kit
	652212	W 1301 x D 700 x H 630 - 1280 mm 2 levels for 6 bins 600 x 400 mm	25 days	In kit
1	690212	Pull handle L 143 x W 20 x D 50 mm	5 days	Per unit
1	690216	Pull handle L 235 x W 40 x D 75 mm	5 days	Per unit
2	541056	Set of 4 swivel roller wheels with brake Ø 75 mm M8 axis	On stock	In batch